

Remember, each site is different. Controls need to be assessed on a site-by-site basis as well as for different activities.

EROSION AND SEDIMENT CONTROL - THE BASICS

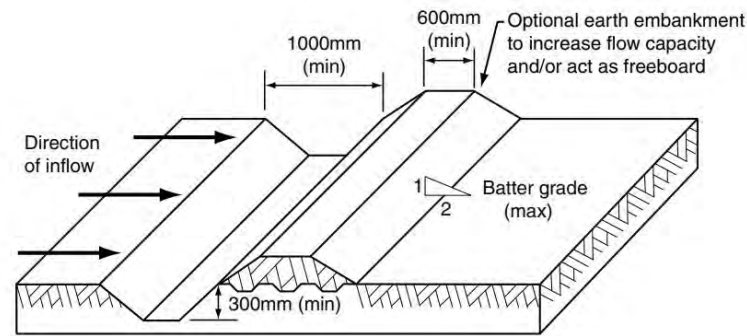

1. Diversion drain. The drain channel must be at least 150 mm deep with a curved shape that will be site specific. Stabilise the flow path to protect it from scour by lining the drain with matting or rock. If dispersive soils are present, create diversion drains by building soil berms instead of digging.

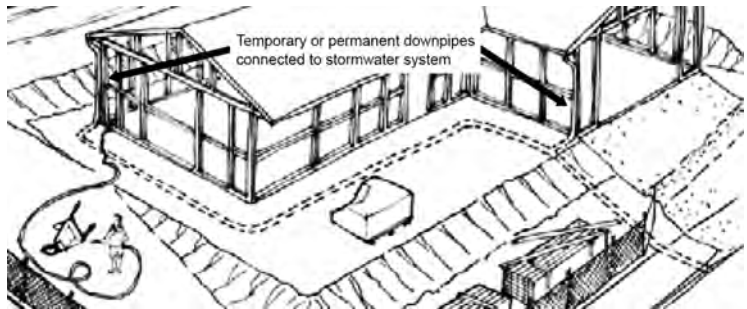

2. Early drainage connection. Connect downpipes and other drainage to the stormwater system as soon as the roof is on and / or other impervious surfaces are constructed, such as driveways, parking areas, or the building slab. Temporary flexible downpipes can be useful until permanent pipes and drainage system is in place.

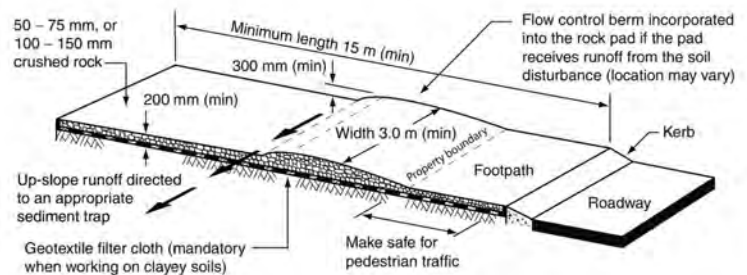

3. Stabilised site access. Stabilised access is from the site boundary to a formal stockpile area or work site; minimum length for small developments is 10 m. Strip at least 150 mm of topsoil, cover with geotextile then a 200 mm thick pad. Divert water from this control to appropriate sediment controls.

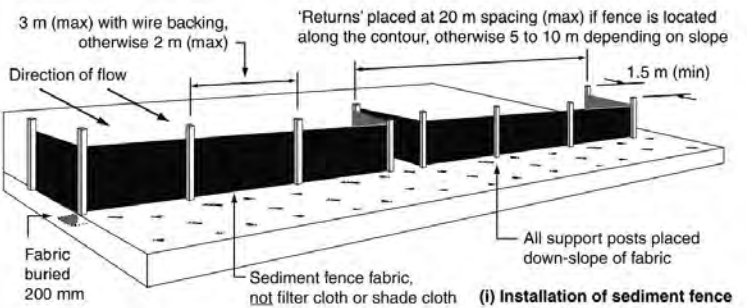

4. Sediment fences. Install parallel to the contour with ends angled upwards. Bury fabric 200 mm deep. Join sections of fabric at a support post with a 2 m overlap. Ensure fabric is securely attached to all support posts. Not suitable for concentrated flow paths, creeks, or major drainage lines.

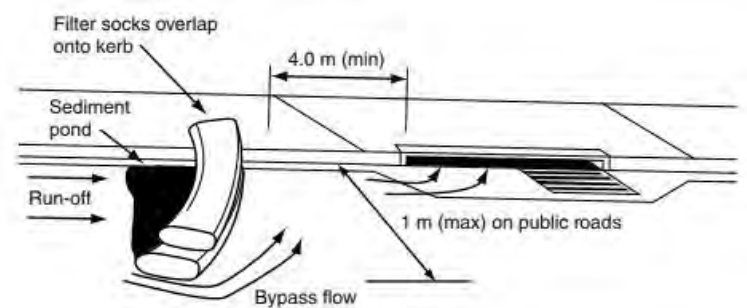

5. Stormwater pit protection. These controls are your last line of defence to protect the stormwater system by placing controls around or inside stormwater pits on site (private) and off site (public). Sediment fences, filter socks, or stormwater pits traps could be used depending on the site specific situation. Filter socks are permeable synthetic socks filled with sand, compost, straw, or aggregate, placed in the pathway of runoff. Place cones around controls in the gutters or on roads to prevent vehicles damaging them.

Everyone working on development sites is responsible for preventing sediment pollution caused by erosion. Follow the practices described below to help minimise erosion on your site, meet your legal requirements, and help protect our waterways.



Drainage controls divert upslope runoff around your site, reducing the amount of water needing to be treated.

Drainage controls include diversion channels, scour protection, and early installation of roof drainage.



Erosion controls stop soil on site from moving in the first place.

Erosion controls include minimising soil disturbance, keeping existing plants and vegetation, revegetating as you go, using erosion mats and blankets, and protecting stockpiles.



Sediment controls capture soil that is already eroding and prevent it from leaving your site.

Sediment controls include stabilised site access, sediment fences, protecting stormwater pits, and rock filter dams.

Key steps to effective erosion and sediment control:

- Have an Erosion and Sediment Control Plan (E&SCP) and make sure everyone working on site understands and maintains it.
- Install erosion and sediment controls before the start of any ground disturbance.
- Minimise the area of soil disturbed and exposed to erosion at any one time.
- Preserve existing vegetation.
- Divert 'clean' runoff away from the work site but not onto other property.
- If sediment does accidentally become mobile, capture and clean runoff before it leaves your site.
- Revegetate disturbed areas quickly.
- Inspect and maintain your erosion and sediment controls throughout the project. Maintenance is key.

We acknowledge the Tasmanian Aboriginal People as the traditional owners and ongoing custodians of Tasmania. We pay our respect to all Aboriginal and Torres Strait Islander peoples and to their Elders past and present.



Here are the basics to reduce erosion and control sediment on your site.

All builders and developers are responsible for erosion and sediment control during each phase of a development. Having a practical understanding of erosion and sediment control will help you meet your legal responsibilities and protect the environment.

Under Tasmanian law* and each council's stormwater management strategy you must control sediment on your site so that it does not cause an environmental nuisance, environmental harm, or property damage.

Effective erosion and sediment control also protects local waterways and the species that live there from sediment pollution. Sediment can carry other pollutants such as cement and metals. You will also be preventing the stormwater system from becoming clogged, potentially causing increased flooding.

For more information about your legal responsibilities, controls and how to install them, download *Erosion and Sediment Control - The fundamentals for development in Tasmania* from the TEER Program or Derwent Estuary Program websites. Page numbers in the captions below refer to that document.

TEER Program | www.teer.org.au

Derwent Estuary Program | www.derwentestuary.org.au

11. EARLY DRAINAGE CONNECTION (pg. 32)

Connect downpipes and other stormwater drains to flat protected areas or to the site stormwater connection as soon as impervious areas are created, such as the slab, the roof, or the driveway. This prevents clean rainwater flowing into disturbed areas, saving you time and money. There may need to be well secured temporary flexible tubing until the permanent system can be installed, which should be done as soon as possible.

10. DIVERT UP-SLOPE RUNOFF (pg. 26)

Divert up-slope runoff away from the disturbed areas of your site. You must NOT divert runoff onto adjacent lots. Surface drainage controls must be removed before completion of the development.

9. PROTECTED SLURRY AND CLEAN-UP AREA (pg. 64)

Clean all equipment, including that with concrete waste, in a protected area that will contain all wastewater and residue and that does not drain to the stormwater system. The designated clean-up area is best located close to your stockpile area.

8. SPRAY-ON SOIL STABILISERS (pg. 41)

Soil stabilisers will help prevent erosion. The longevity of products varies, usually 2-3 months if ground is not disturbed. Choose a stabiliser according to the duration of protection required.

1. LIMIT DISTURBANCE WHEN EXCAVATING (pg. 34)

Keep earthworks to the minimum area required and timed with the commencement of building and construction work. To minimise erosion risks, keep and protect existing topsoil and vegetation. Stabilise slopes once exposed / disturbed as soon as possible; they may need to be roughened and terraced, and covered with erosion control blankets, turf, hydromulch, or soil binder.

2. STORE ALL HARD WASTE IN A DESIGNATED AREA (pg. 53)

Store all hard waste and litter on the site in a way that will prevent it being blown away or washed into the stormwater system - in a skip bin, fenced, banded, and covered area.

3. STABILISED SITE ACCESS (pg. 56)

Restrict vehicle movement onto the site to a single stabilised access point. This allows all-weather entry and exit and reduces how much soil is carried to the street. It should lead to or be adjacent to your formal stockpile and hard waste areas.

4. INSTALL SEDIMENT FENCES (pg. 67)

Install sediment fences / mulch bunds downslope of all disturbed land to catch coarse sediment. These controls do not stop finer sediment from escaping.

5. PROTECT STORMWATER CONNECTION PIT (pg. 61)

This is your last line of defence against sediment escaping. Protect the stormwater system from blockage and accumulation of sediment / building debris using sediment fences / mulch bunds, filter socks and stormwater pit traps.

6. LEAVE THE NATURE STRIP VEGETATED (pg. 38)

Protect plants on the nature strip, even if it's just grass, from being driven or parked on. This is one of the most effective things you can do to reduce erosion.

7. PROTECT STOCKPILES (pg. 47)

Unprotected stockpiles are at risk of being washed or blown away. Place stockpiles away from on-site drainage or overland flow paths. Install sediment fences / mulch bunds downslope and cover stockpiles with fabric, plastic, or temporary grass cover. Stockpile materials should be delivered directly to the protected stockpile area.

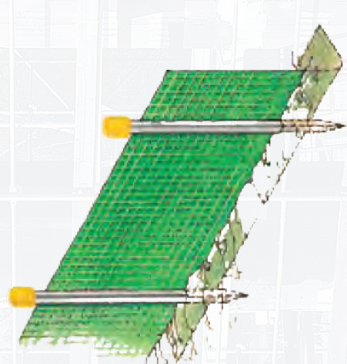
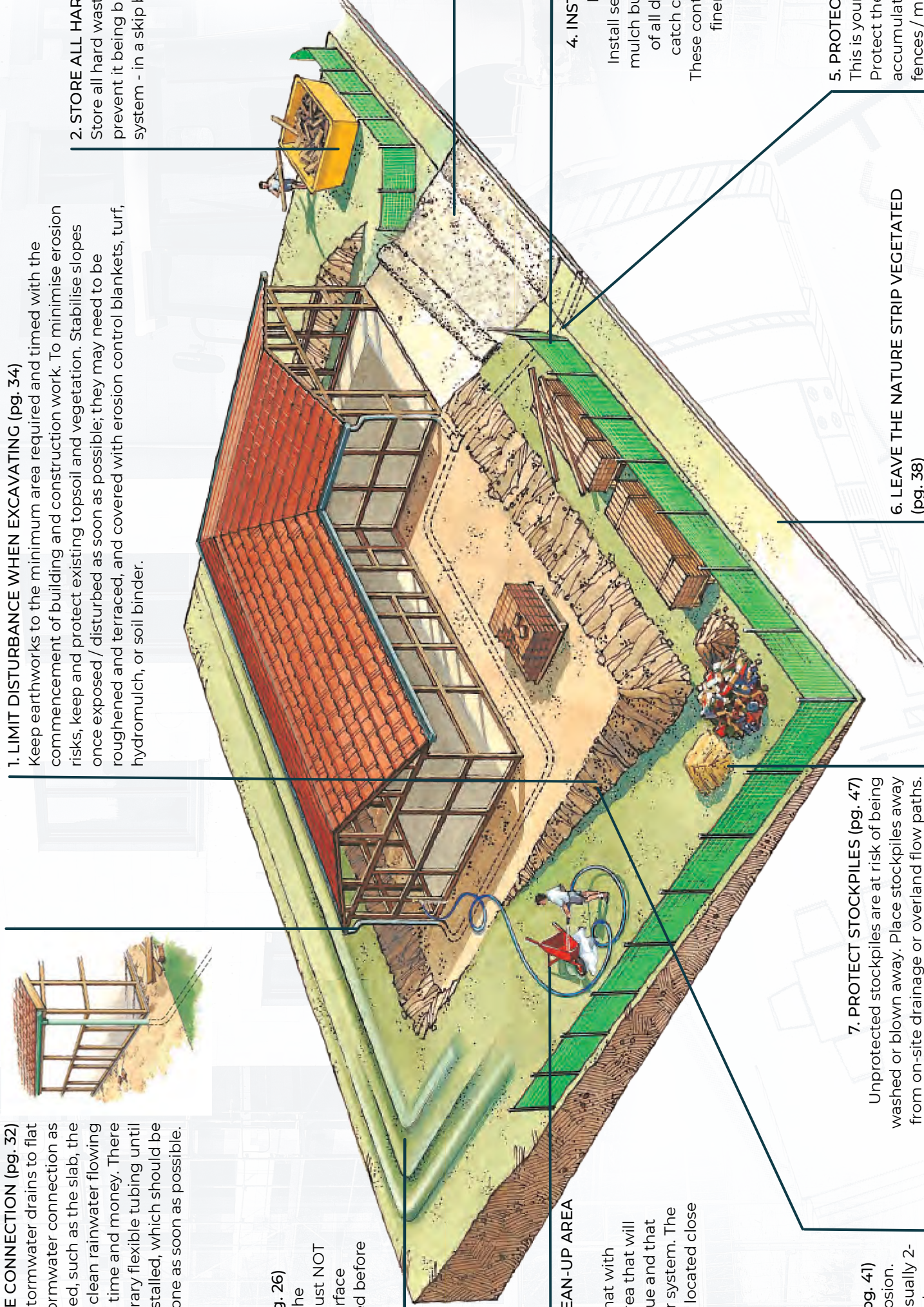

* Including planning permits issued under the *Land Use Planning and Approvals Act 1993*, and requirements of the *Building Act 2016*, *Urban Drainage Act 2013*, *Environmental Management and Pollution Control Act 1994*, *State Policy for Water Quality Management 1997*, or future equivalents.